



TOWBAR INSTALLATION INSTRUCTIONS

PART NUMBER 03447W

RENAULT CAPTUR XJB CL2



PRODUCT DETAILS:

Part Number:	03447W	Maximum Towing Braked:	1200	kg
ECU Number:	04836	Maximum Towing Unbraked:	750	kg
Tail Harness Length Required:	400 mm	Maximum Static Ball Load:	75	kg
TBM/Lug Part Number:	07756			
Wiring Part Number:	102815-WL			

FITTING DETAILS:

Towbar Installation Time:	90 Mins.	Hayman Reese SmartCODE Solution Required:	NO
Wiring Installation Time:	60 Mins.	RPA Disable/Other:	NO
Total Installation Time:	150 Mins.		
Bumper Cut Required:	Yes	Note:	

- RPA Disable near transmission lever.



TOWBAR INSTALLATION INSTRUCTIONS

PART NUMBER 03447W

RENAULT CAPTUR XJB CL2

ENSURE THAT INSTRUCTIONS ARE UNDERSTOOD PRIOR TO FITMENT.

i BEFORE YOU START:

Hayman Reese recommends that instructions are read completely prior to fitment. Check all hardware items have been included refer to assembly diagram. Please ensure this towbar is only fitted to vehicle models as per Hayman Reese application guide (www.haymanreese.com.au).

Bumper Cuts



Vehicle and bumper variations can and do occur during vehicle manufacture after initial towbar design. Fitment of towbar to vehicle and accuracy of bumper cut must be assessed prior to any bumper modifications made. Incorrect bumper cuts are not covered under Hayman Reese warranty.

NOTE: Bumper cuts need to be approached with care, refer to notes below.

- Bumper centreline – where the centreline of the bumper needs to be determined, the installer must assess centre point by measurement of bumper width or determining two symmetrical reference points to give centreline.
- Bumper edge – To assist with accurate bumper cut measurement, reference to the start of the bumper edge is now being commonly used.
 - Measure from bottom edge along bumper and around corner to the 70 mm point (Figure 1).
 - Do not measure from visible bumper front of corner, upwards (Figure 2).

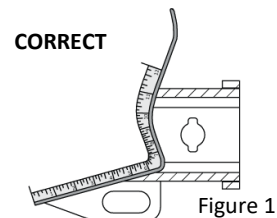

Figure 1

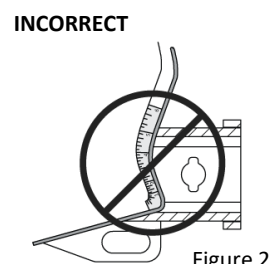

Figure 2

Drilling

- For any required drilling during installation, ensure that the area is clear of fuel, electrical & other components that may be damaged.
- All holes drilled into the body panels shall have all burrs & swarf removed then coated with a suitable rust preventative paint.

Bolts/Fasteners

- Ensure that all hardware is fastened to correct torque as specified in this fitting instruction.
- All fasteners supplied with this product are used to achieve a specified clamp loading. If replacement is required ensure that fasteners of the same grade and class are used.



NOTE: Achieving correct torque is critical to proper installation and responsibility of the installer. Towbar failures attributed to tension issues from over tightening or under tightening are not covered by Hayman Reese warranty.

Product Labels

- a. Towbar load rating sticker provided with this product shall be conspicuously located on inside rear end of the driver's door.
- b. Powertrain Control Module (PCM)/Body Control Module (BCM) upgrade warning label will be provided in towbar kit for vehicles as required. Affix warning label in door and owner's handbook.

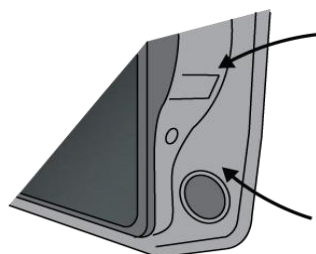

Place **Load Rating sticker** inside driver's door here

Place **Vehicle PCM/ BCM upgrade warning label** in door AND on front cover of owner's service handbook

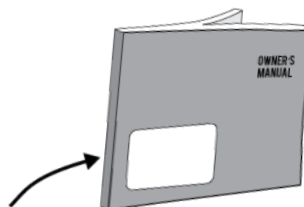

WARNING:

Do not, drill, cut, weld or otherwise modify the towbar.

FOR TOWING PURPOSES ONLY - This towbar is designed and tested by Hayman Reese to adhere to ADR 62/02 which provides only for the expected load demands of towing.



TOWBAR INSTALLATION INSTRUCTIONS

PART NUMBER 03447W

RENAULT CAPTUR XJB CL2

i TOWBAR ASSEMBLY DIAGRAM

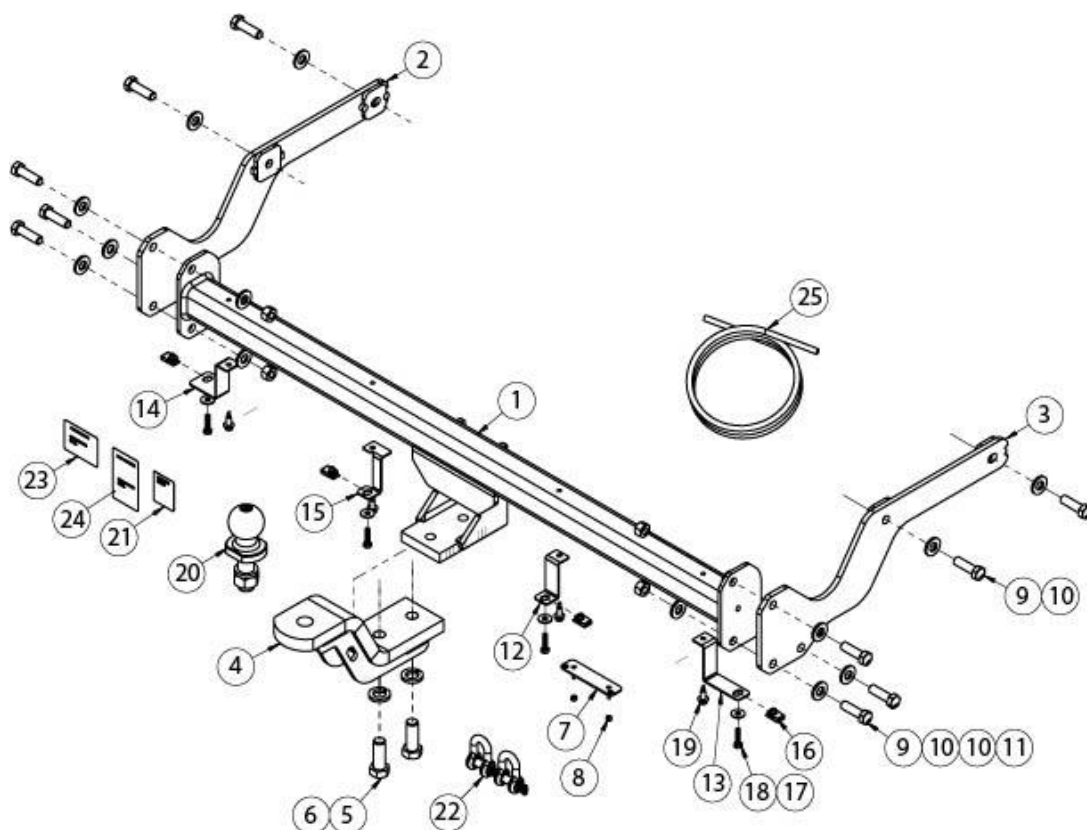

ITEM	DESCRIPTION	QTY
1	RENAULT CAPTUR XJB TOWBAR	1
2	SIDE ARM LHS ASSY	1
3	SIDE ARM RHS ASSY	1
4	TRAILER BALL MOUNT	1
5	BOLT HEX HD M16x45x2.0P	2
6	WASHER SPRING M16x5x3.5	2
7	PLUG BRACKET	1
8	NUT NYLOC HEX HD M4x0.7P	2
9	SET SCREW HEX HD M12x40x1.75P	10
10	WASHER PLAIN 1/2"	16
11	NUT HEX HD M12x1.75P	6
12	BUMPER MOUNT RHS INNER	1
13	BUMPER MOUNT RHS OUTER	1

ITEM	DESCRIPTION	QTY
14	BUMPER MOUNT LHS OUTER	1
15	BUMPER MOUNT LHS INNER	1
16	CLIP NUT 6MM	4
17	WASHER PLAIN 1/4x3/4x16	4
18	SET SCREW HEX HD M6x25x1.0P	4
19	TEK SCREW 14-20 HEX HD 22mm	4
20	TOWBALL 50mm	1
21	HAYMAN REESE LOGO STICKER	1
22	"D" SHACKLE 10mm	2
23	COMPLIANCE LABEL	1
24	LOAD RATING LABEL	1
25	WIRING LOOM	1



TOWBAR INSTALLATION INSTRUCTIONS

PART NUMBER 03447W

RENAULT CAPTUR XJB CL2

1. Open Tailgate, open flap and unscrew, remove and disconnect the taillight store in safe location

Repeat for other side.

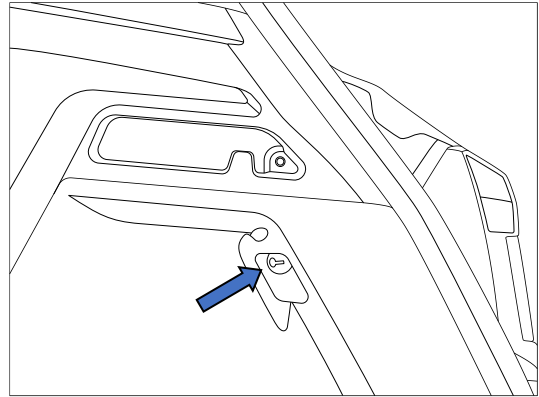

2. Remove screw and scrivet from bumper bar.

Repeat for other side.

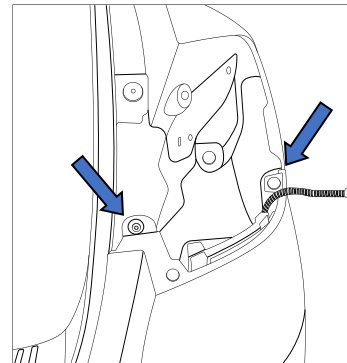

3. Remove 2 x Screws from Wheel Arch

Repeat for other side.

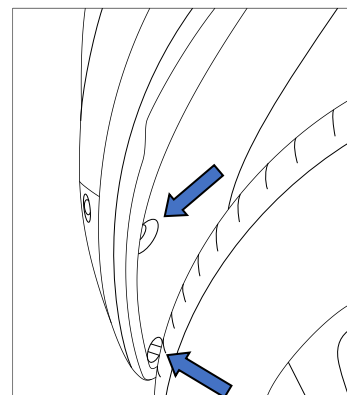



TOWBAR INSTALLATION INSTRUCTIONS

PART NUMBER 03447W

RENAULT CAPTUR XJB CL2

-
4. Remove 3 x screws from lower corner of bumper bar.

Repeat for other side.

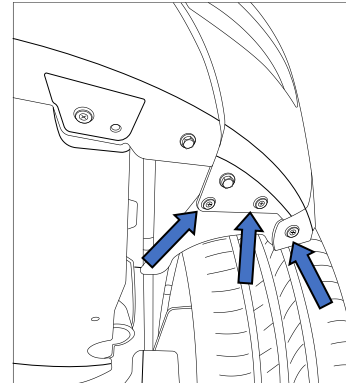

-
5. Unclip Wheel Arch Trim.
Take care not to Bend

Repeat for other side.

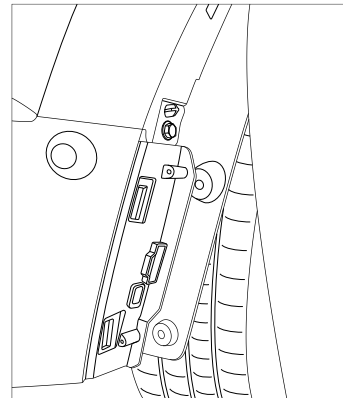

-
6. Remove screw from leading edge of Bumper.

Repeat for other side.

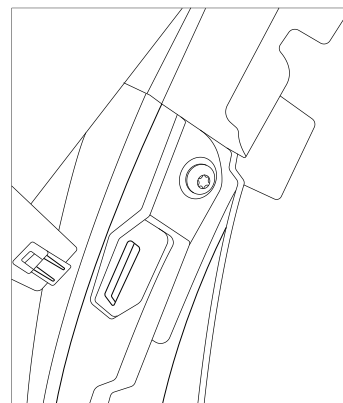

-
7. Remove 4 x Screws retaining bumper to under tray

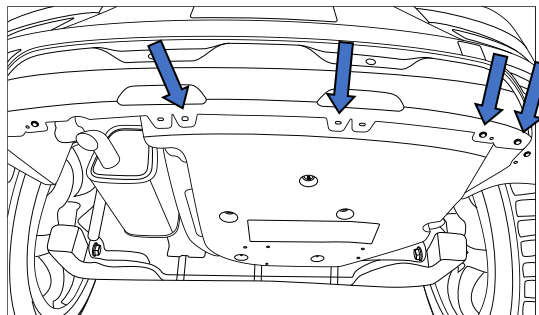

-
8. Remove 6 x Speed nuts and remove undertray.

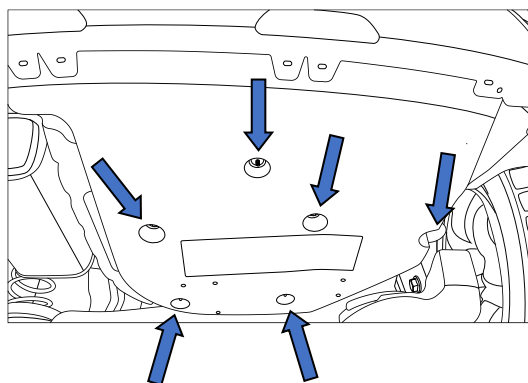

-
9. Peel bumper away from the sides and remove bumper. Ensure to disconnect any wiring looms.

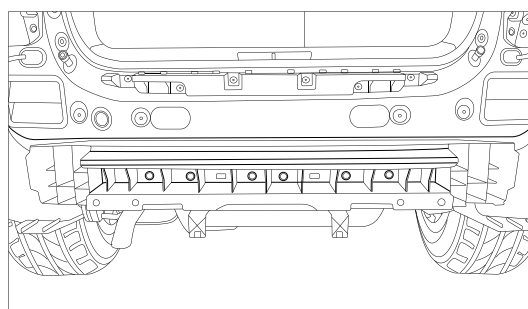



TOWBAR INSTALLATION INSTRUCTIONS

PART NUMBER 03447W

RENAULT CAPTUR XJB CL2

10. Remove 2 x Bolts retaining Impact Beam

Repeat for other side.

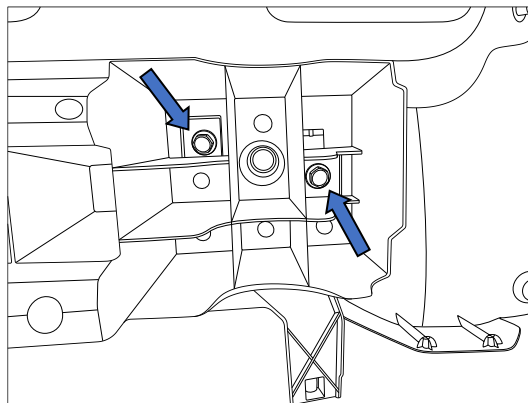

11. Remove impact beam and discard.

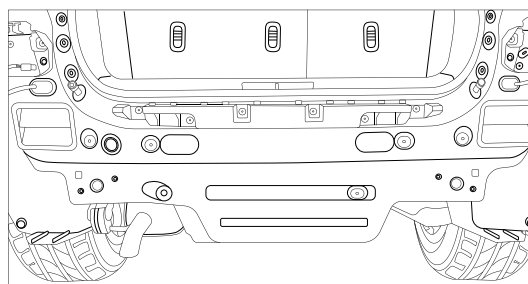

12. Remove 2 x Adhesive Stickers covering captive nuts on the outside of chassis Rails.

Repeat for other side.

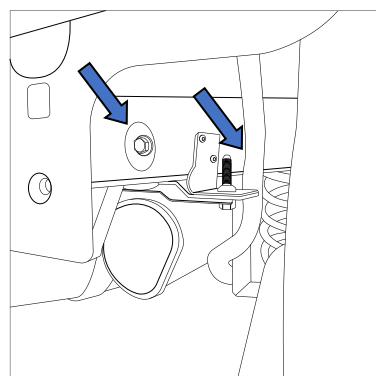



TOWBAR INSTALLATION INSTRUCTIONS

PART NUMBER 03447W

RENAULT CAPTUR XJB CL2

13. Fit Side Arm Assy to outside of Chassis Rail using 2 x M12 Bolt and Washer

Repeat for other side.

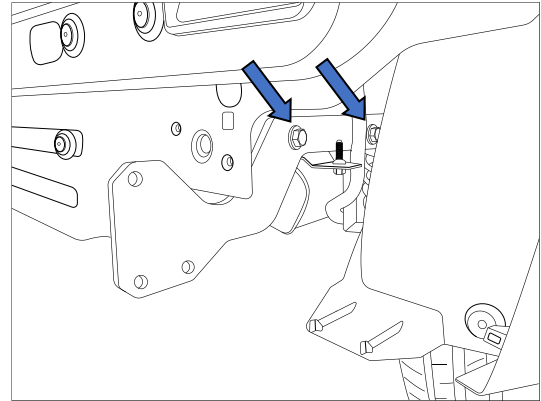

14. Raise the crosstube to the side arms and loosely secure each side with 3 x M12 bolts complete with 2 x washer and 1 x M12 nut per bolt.

Repeat for other side

Position the towbar and tighten all fasteners to the following Torques:

M12 : 109Nm

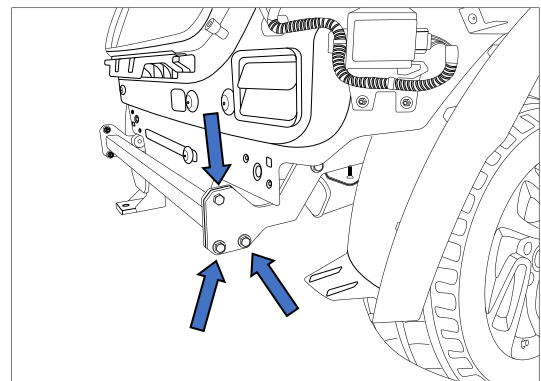

15. Fit Bumper tabs to towbar cross tube with Tek Screws

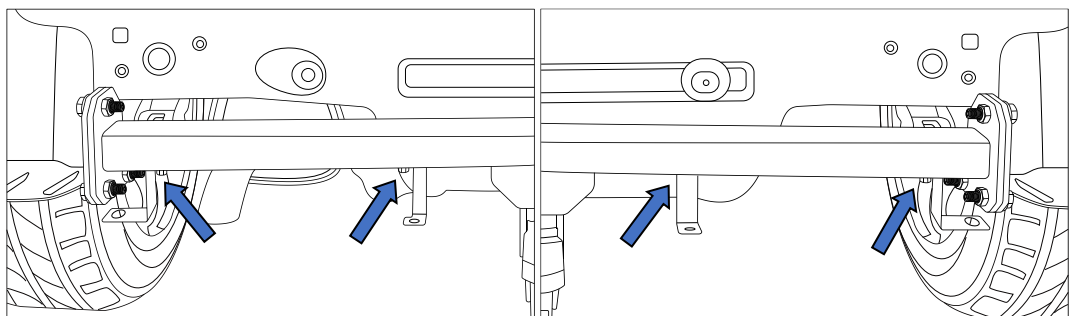



TOWBAR INSTALLATION INSTRUCTIONS

PART NUMBER 03447W

RENAULT CAPTUR XJB CL2

16. Install 1 x U-nut per bumper TAB.

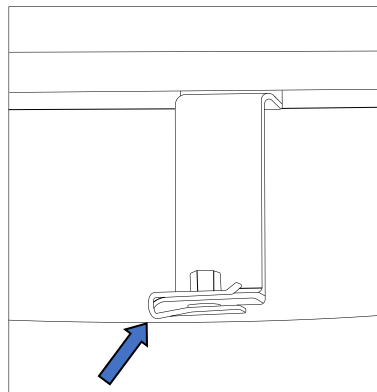

17. With the towbar assembled, partially install the undertray and mark the center of the towbar on the undertray.

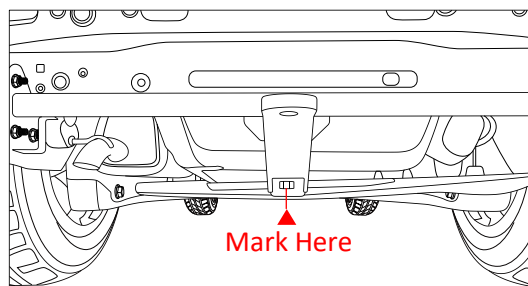

18. Measure 55mm either side, 110mm in total mark up and cut the underliner as shown.

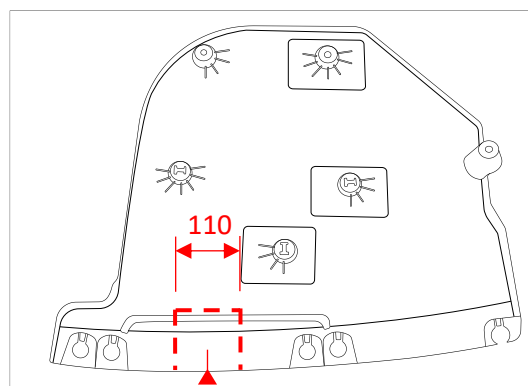



TOWBAR INSTALLATION INSTRUCTIONS

PART NUMBER 03447W

RENAULT CAPTUR XJB CL2

IMPORTANT

Due to possible vehicle variations, always confirm any noted vehicle colour wires with a multi-meter to ensure the correct function is identified before soldering or scotch locking. For vehicle wires denoted with two colours (example; RED/GREEN) the first colour will always be the main wire colour while the second colour is the thinner trace colour on the wire.

19. Dislodge and remove front passenger door seal trim (1) and dash panel plastic trim (2).

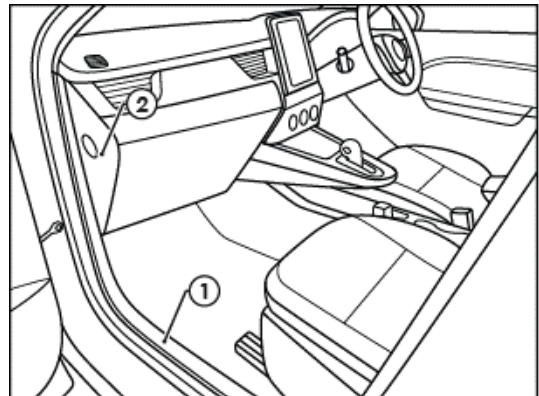

20. Dislodge and remove left rear passenger door seal trim (1) and C-pillar upholstery (2).
21. Dislodge B-pillar trim (3) only.

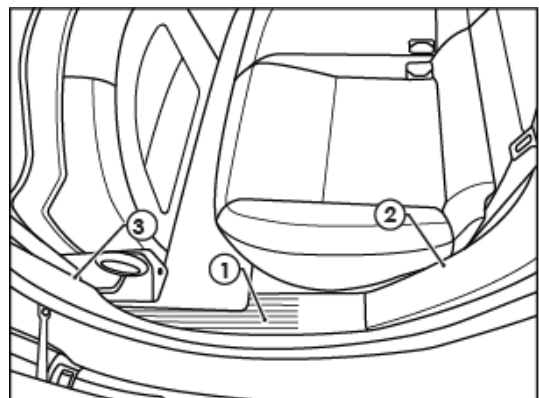

-
22. Unfasten x2 large torx screws (1).
 23. Dislodge and remove Rear Scuff Panel (2).

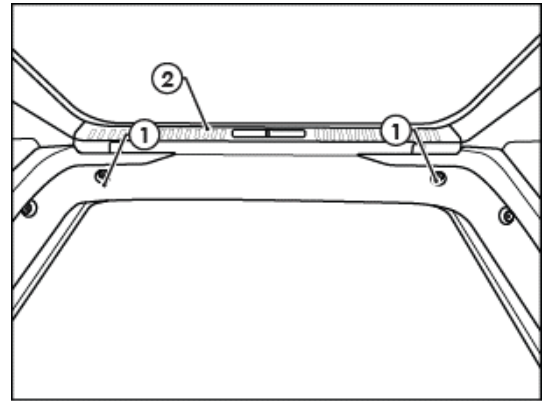

-
24. Unfasten large torx screw (1) and x2 small screws (2).
 25. Dislodge and remove LHS boot trim (3).

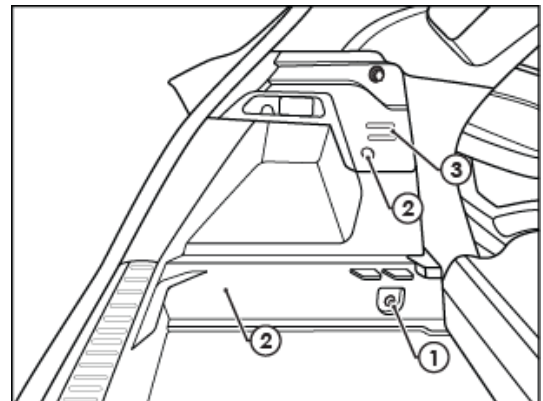

-
26. Begin installation of the harness on the Rear LHS. Orientate the harness so that the fuse link is forward of the vehicle and the grommet is rearwards of the vehicle.
 27. Locate and disconnect the 10-way male and female connectors (1) in the rear and replace with the 10-way male and female connector on the harness supplied in the kit to create a 'Y' shape.

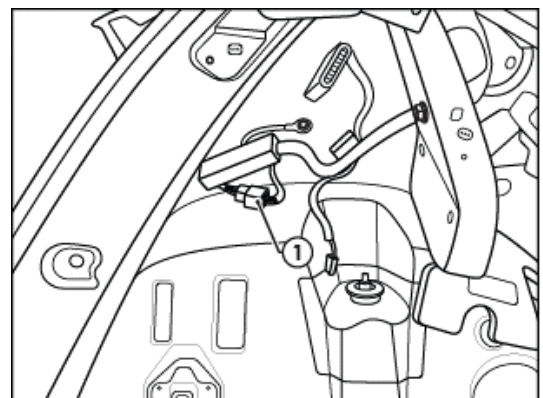
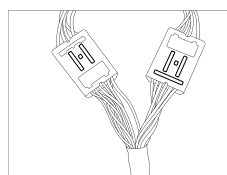

28. Unfasten the nut of the earth stud (1), slide the ring terminal of the harness onto the stud and refasten the nut without disturbing the other ring terminal.
29. Using double sided adhesive foam tape supplied in the kit, apply Double Adhesive Foam Tape for Trailer ECU (3).
30. Connect the 12-Way (2) connector to the Trailer ECU (3).
31. Place Trailer ECU (3) in location that ensures good adhesion.

Note: Mount the ECU, ensuring the connector is orientated downwards.

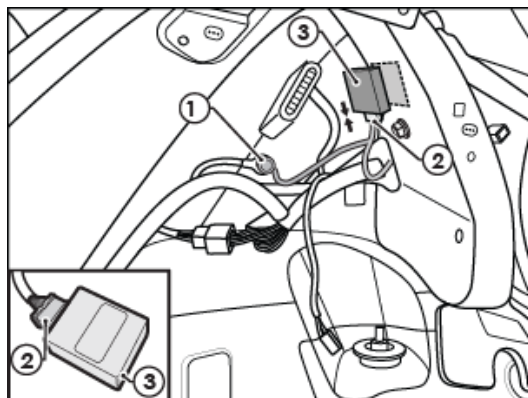

32. Route the harness through the hole above the wheel arch (2) and then down towards the rear passenger seat.
33. Secure harness to vehicle main harness with cable ties.

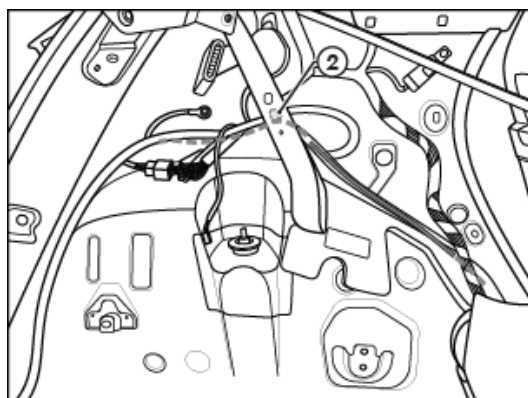

34. Route the harness (1) under the rear passenger door seal trim.
35. Secure harness to vehicle main harness with cable ties.

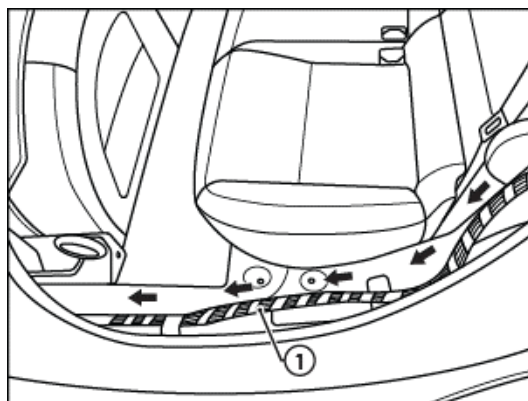



TOWBAR INSTALLATION INSTRUCTIONS

PART NUMBER 03447W

RENAULT CAPTUR XJB CL2

36. Pass the harness under the B-Pillar Trim (1).
37. Route the harness under the front passenger door seal trim and up behind the glove box.
38. Secure to existing harness with the cable ties supplied within the kit.

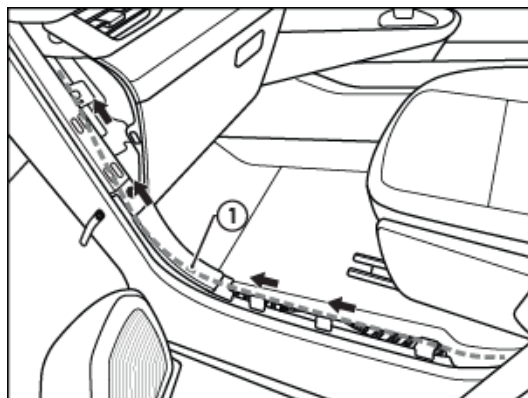

39. Open glove box and remove fuse box cover.
40. Locate fuse using diagram and remove (15A Blue Fuse at Location #9) (A).

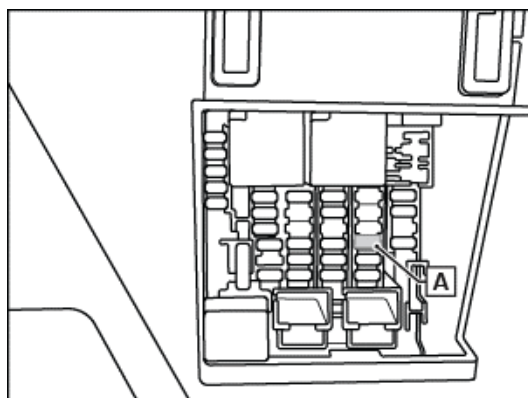
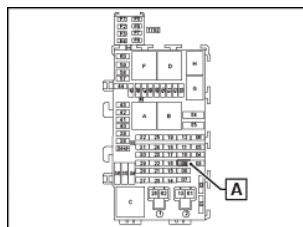

41. Connect Fuse Link (1) to harness (2). Insert 20A (3) into top slot of fuse link.
42. Insert the 15A Fuse, previously removed from fuse box, into the bottom slot of the fuse link provided on the harness and place back in fuse location #9 as per image.

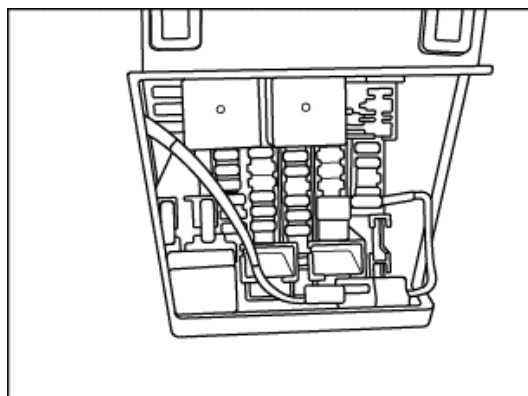
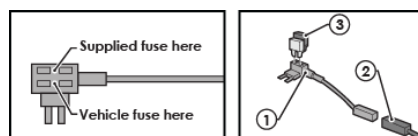

-
43. Remove the 40mm grommet (1) from the back of the vehicle.

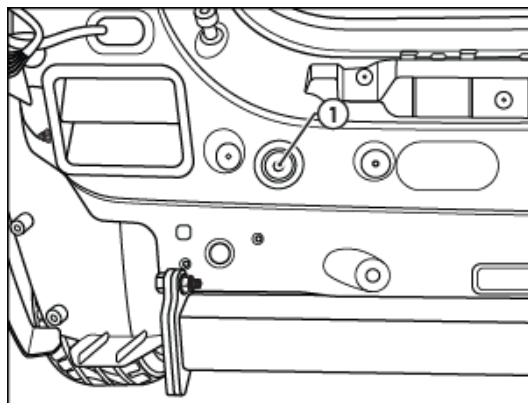

-
44. Route the other end of the harness (1) through the hole in the sheet metal of the boot and out of the hole where the grommet has been removed.

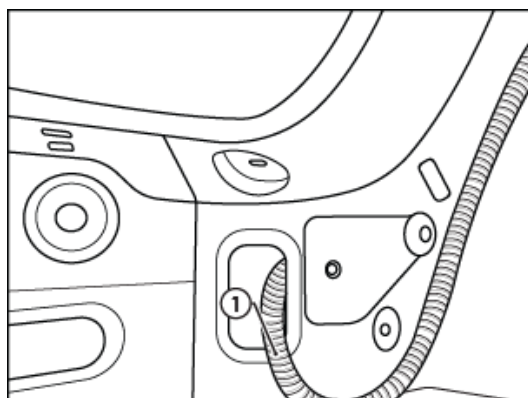

-
45. Pull the harness through and until the grommet of the harness has been seated correctly in the hole (1).

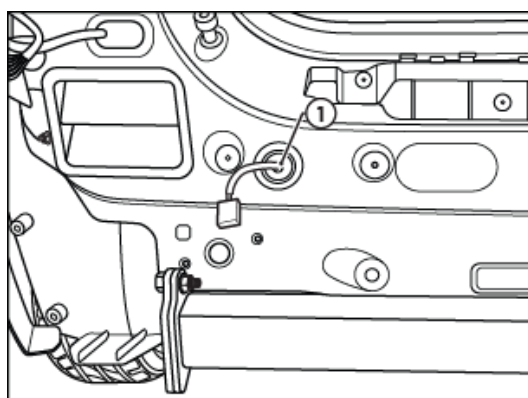



TOWBAR INSTALLATION INSTRUCTIONS

PART NUMBER 03447W

RENAULT CAPTUR XJB CL2

46. Connect the tail harness (tail length 400mm) 8-way connector (1) to the trailer patch mating 8-way connector (2).
47. Waterproof the trailer patch 8-way connector (1) and the tail harness 8-way male connector (2) using silicone grease (3) (not supplied).
48. Secure all harness using supplied cable ties.
49. Test the trailer patch function using a light board or multi-meter.
50. Re-Install the removed parts in reverse order bumper by following steps 1-9, 19-25 in reverse order.
51. Re-fit all removed parts and secure all fasteners, ensuring there are no squeaks or rattles.
52. The RPA function can be disabled via a switch next to the gear shifter.
53. Place the fitting instructions in the glove box after fitment.

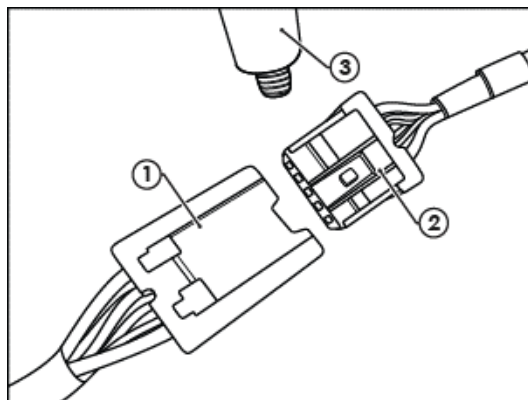



CUSTOMER INFORMATION

PLACE THESE INSTRUCTIONS IN THE
VEHICLE'S GLOVEBOX AFTER INSTALLATION

**THANK YOU FOR PURCHASING HAYMAN REESE.
WITH CORRECT MAINTENANCE AND CARE THIS PRODUCT WILL PROVIDE A
LIFETIME OF TROUBLE-FREE OPERATION.**

i TOWBAR MAINTENANCE AND CARE:

1. Hayman Reese recommend that the towbar LUG or TBM (tow ball Mount) Pull Pin and R-clip are removed and stored when not in use. Removal of LUG or TBM (tow ball mount) is advisable when not in use to assist with any of the following.
 - Ensure rear number plate is not obscured.
 - Allow maximum available departure angle and prevent any potential interference.
 - Prevent possible interference with vehicles reverse sensors or camera detecting a tow ball mount as an obstruction during reversing.
 - Removes towball mount as an obstruction for when moving around the rear of the vehicle.
2. Hayman Reese recommends routine inspection of your towbar to ensure trouble free towing.
 - Bolt security and tension should be regularly inspected and checked for correct tension. Replace any worn or defective parts with suitable grade & class fasteners. Inspection should be requested to coincide with vehicle major services.
3. It is the owner's responsibility to ensure towing and down ball weight capacities of the towing vehicle are not exceeded.
 - Towing and down ball weights allowable may differ according to model variations. Please refer to owner's manual or vehicle dealer to confirm exact rating for your vehicle model variant.
 - It is not uncommon for the vehicle tow rating to differ from the towbar rating. When this occurs, the lesser rating must be adhered to.
 - For vehicles fitted with enhanced vehicle functions that may be altered/changed when towing i.e Trailer sway mitigation, blind spot detection, adaptive cruise control etc. Please consult owner's manual to understand changes enabled when towing and after towing.

i WARRANTY INFORMATION:

Hayman Reese Towbars are covered by a Lifetime Warranty.

Our goods come with guarantees that cannot be excluded under the Australian Consumer Law. You are entitled to a replacement or refund for a major failure and for compensation for any other reasonably foreseeable loss or damage. You are also entitled to have the goods repaired or replaced if the goods fail to be of acceptable quality and the failure does not amount to a major failure.

For further details please visit www.haymanreese.com.au/warranty or contact customer service on 1800 812 017 or info@haymanreese.com.au.



CUSTOMER INFORMATION

PLACE THESE INSTRUCTIONS IN THE VEHICLE'S GLOVEBOX AFTER INSTALLATION

HAYMAN REESE SMART PIN

Your Hayman Reese towbar is equipped with Smart Pin technology to help reduce towbar tongue rattle in most driving conditions. Please ensure below instructions are understood and routine maintenance is carried out to ensure best towing experience.

i Regularly inspect for wear and check the tightness of the Smart Pin Nut. Follow instructions below to re-tighten the nut as necessary when movement and noise in the tow ball mount is noted.

- Before towing, ensure R-Clip is properly installed and Smart pin nut is installed and tensioned. Replacement parts are available from your Hayman Reese Distributor.

TOWBALL MOUNT REMOVAL/INSTALLATION

STEP 1

Insert Trailer Ball Mount (TBM) (a) into towbar hitchbox (b), aligning hole in TBM shank (c) with hole in hitchbox (d) (Fig. 1)

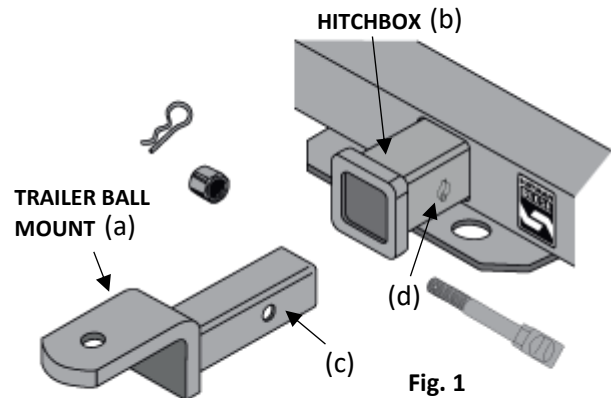

STEP 2

Insert Smart Pin (e) through hole in hitchbox and hole in TBM shank (g); ensure the locators are inserted into the notches in the hitchbox (Fig. 2)

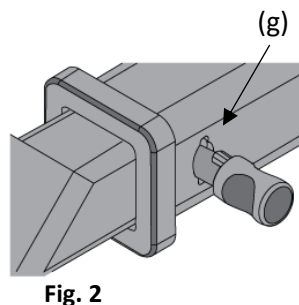

STEP 3

Screw Smart Pin Nut (f) onto Smart Pin (g); tighten Smart Pin Nut until finger tight, ensuring TBM is restrained from up and down movement.

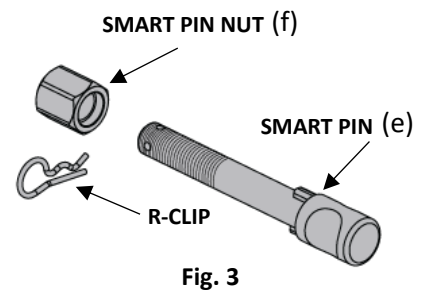

STEP 4

Tighten Smart Pin Nut by turning nut a further 1/8th of a turn in the clockwise direction using a 24mm spanner (Fig. 4).

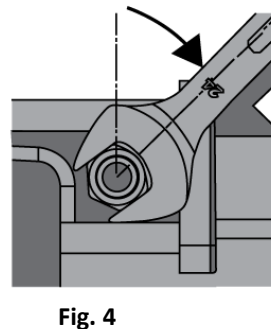

STEP 5

Install Smart Pin R-Clip through the hole that provides best clearance or easiest access. (Fig. 5)

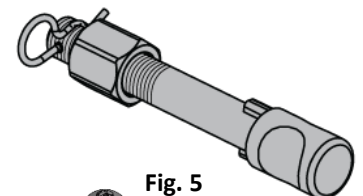

STEP 6

Install towball onto TBM and tighten to **350 Nm** using a calibrated torque wrench (Fig. 6).

