

# Fitting Instructions



SKU

**TXR850**

PRODUCT

**TAG 4x4 Recovery Towbar for Mitsubishi Triton (Styleside Ute 05/2015 – on)**

SPECIFICATIONS

- Towbar Class: CL 7 Extreme Recovery
- Towing Capacity: 3100kg
- Tow ball Weight: 310kg
- Approx. Fitment Time: 40 Minutes



Scan for latest version of these instructions

TOOLS REQUIRED

- Spanners
- Sockets
- Torque Wrench

IN THIS GUIDE

- Fitment Instructions
- Torque Settings
- Warranty Info

# Towbar Assembly

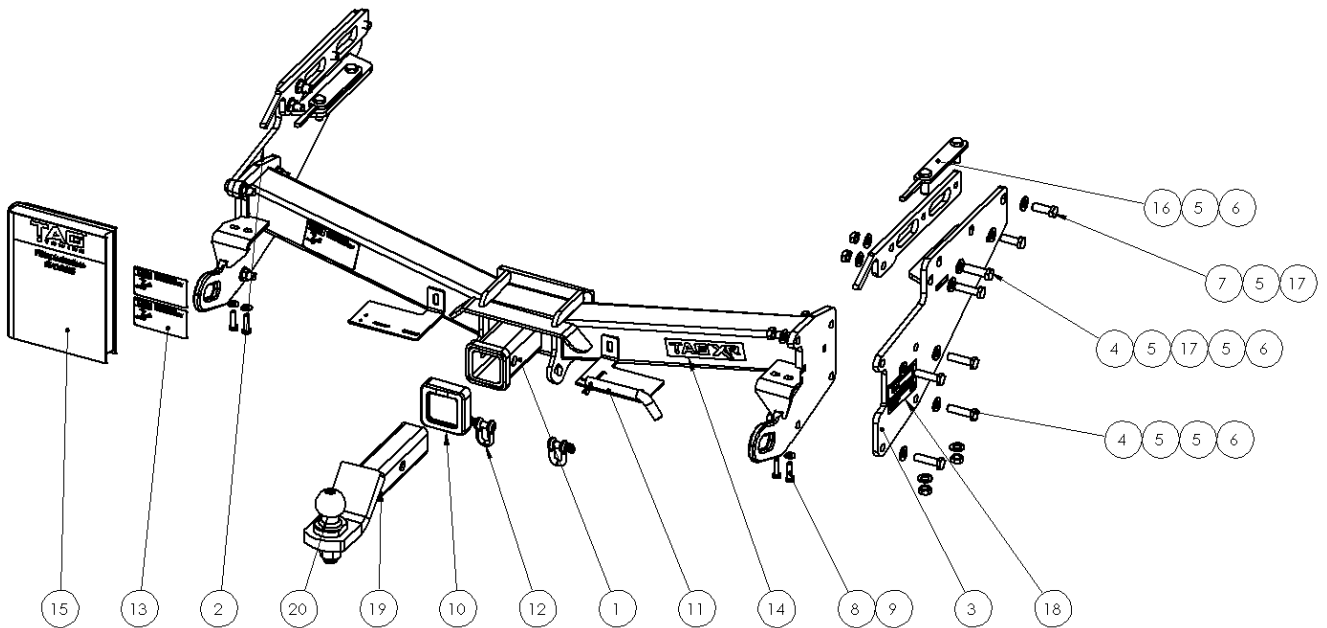

ITEM NO.	DESCRIPTION	QTY.	ITEM NO.	DESCRIPTION	QTY.
1	Towbar Assembly	1	11	Class 4 Pin & Clip	1
2	Endplate Assembly	1	12	D-Shackle - 10mm. 1000kg	2
3	Endplate Assembly DS	1	13	TAG Compliance Sticker	3
4	M12 x 1.25 x 45 Bolt	12	14	TAG XR Sticker 150 x 33mm	1
5	M12 Flat Washer	32	15	Fitting Instruction	1
6	M12 x 1.25 Nut	16	16	Internal Chassis Bolt Plate	2
7	M12 x 1.25 x 35 Bolt	4	17	Chassis Bolt Plate	2
8	M8 x 1.25 x 30 Set Screw	4	18	Tag WLL Sticker (Blank)	1
9	M8 Flat Washer	4	19	L4045 POWDER COATED TBM	1
10	TAG Hitch Cover	1	20	50mm TAG Tow Ball - Zinc Plated	1

# Important Information



## Warning:

- This product is for towing purposes only and must only be loaded as shown in your vehicle Owner's Manual.
- This towbar is NOT to be drilled, cut, welded, or modified in any way.
- Check behind chassis rail and body panels before drilling to ensure no hazards are present.
- All load ratings shown are under the assumption your trailer has a functional braking system installed.
- When installed in positions other than the one depicted in these instructions the Tow Ball Mount may interfere or obstruct certain features of your vehicle (tailgate opening, Chassis clearance, etc.)

## General:

- Before fitting this towbar read fitting instructions and check installation hardware is correct.
- Check that the towbar is suitable for the vehicle and be wary of any changes to the vehicle design that may conflict with the fitting of this towbar. (Tray, Canopy, Suspension etc.)
- After drilling, blow any filings clear, remove any burrs and treat exposed metal with a rust inhibitor.
- The high tensile fasteners supplied with this product are an integral feature to achieving the specified rating, if replacement is required ensure that fasteners of the same grade (8.8) & quality are used. Contact an authorised TAG distributor or the TAG fitment center - (07) 3208 3022 - if further information is required.

## Towbar Maintenance and Care:

It is recommended, when not in use, the Tow Ball Mount assembly and class 4 Pin and Clip is stored inside the car away from moisture to prevent standing water from forming rust. Inspect to ensure, on regular basis, fasteners are torqued to the specifications below and in good condition.

Ensure that the fitting instructions are read and understood prior to fitment  
Place these instructions in the vehicle's glovebox after installation is completed.

<i>Metric Bolt Torque Settings</i>										
Diameter	Pitch	Grade	Torque	Unit		Diameter	Pitch	Grade	Torque	Unit
M8	1.25	8.8	29	Nm		M12	1.50	8.8	97	Nm
M10	1.25	8.8	57	Nm		M12	1.75	8.8	77	Nm
M10	1.50	8.8	44	Nm		M14	2.00	8.8	122	Nm
M12	1.25	8.8	101	Nm		M16	2.00	8.8	190	Nm

# Installation Instructions



---

## Step 1: Remove Rear Bumper, Spare Wheel & Drop Exhaust

---

- a. Disconnect the bumper harness on each side of the vehicle. Remove bumper from the chassis drop-down bracket on each side via 2x M8 bolts per side.
- b. Remove and discard the remaining bumper retaining bracket and fasteners from the chassis.

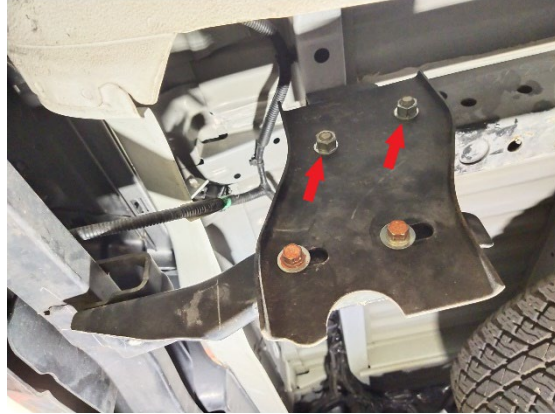
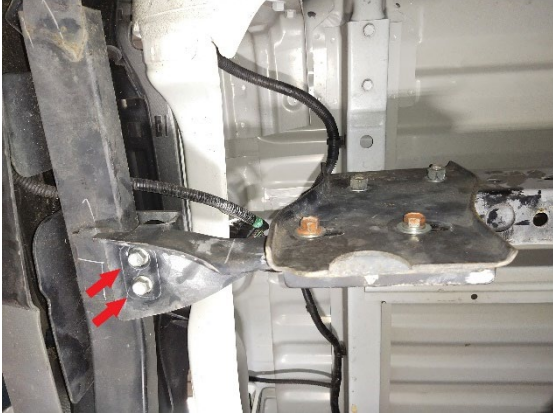

---

## Step 2: Fit Towbar

---

- c. Insert the bolt plates into the chassis to align with holes in bottom side.
- d. Insert the large nut plate (**tapped holes & angled handle**) into the chassis to align with the holes in the side of each chassis.
- e. Lift end plates up to each chassis and loosely secure to the bottom of the rail and previously inserted bolt plate with M12x 1.25 nuts and flat washers.
- f. Insert 2x M12x 1.25x 45 bolts into the 2x rear most side holes of chassis and previously inserted nut plate. Loosely secure with flat washers and nuts on the inside.
- g. Insert M12x 1.25x 35 bolts into the remaining forward most holes and secure loosely.
- h. Lift main bar assembly up to end plates and loosely secure with M12x 1.25x 45 bolts, washers & nuts.
- i. Tighten all bolts to the torque specification on page 3



---

## Step 3: Refit Bumper

---

- Refit the bumper onto the tabs of the main bar and secure loosely with M8x 20 bolts & flat washers.
- Align the bumper to the vehicle and tighten all bolts.
- Attach plastic hitch surround.
- Insert ball mount & secure with pull pin & clip.



---

## Step 4: Apply Compliance Label

---

Apply one of the compliance labels to the pillar of the driver's door. Leave the remaining label and the fitting instructions in the vehicle handbook.



# TAG Warranty Statement



SWD warrants your TAG Towbar for its full product life under the following conditions:

- You can show proof of purchase.
- The towbar has been correctly installed by a suitably qualified installer.
- The towbar has not been modified or abused in any way and has only been used for the purpose intended.
- The towbar was not fitted second hand to your vehicle.

The extent of this warranty includes materials and workmanship used in the manufacture of the towbar and is to the equivalent value of current, full replacement cost.

Nothing stated or implied in this warranty limits in any way, the statutory rights that you may have.

To make a claim visit the original installer in the first instance or, if you are unable to or are not satisfied with their help, then contact us direct by phone on 1300 669122 or visit [www.swd.com.au](http://www.swd.com.au).