

Fitting Instructions



SKU

T4X994

PRODUCT

**TAG Heavy Duty Towbar
for Universal Multi-Fit Truck**

SPECIFICATIONS

- Towbar Class: CL 4 Heavy Duty
- Towing Capacity: 3500kg
- Tow ball Weight: 350kg
- D-Value: 29.4
- Approx. Fitment Time: 90 Minutes



Scan for latest
version of these
instructions

TOOLS REQUIRED

- Spanners
- Sockets
- Torque Wrench
- Drill
- Drill Bits
- Welder

IN THIS GUIDE

- Fitment Instructions
- Torque Settings
- Warranty Info

Towbar Assembly

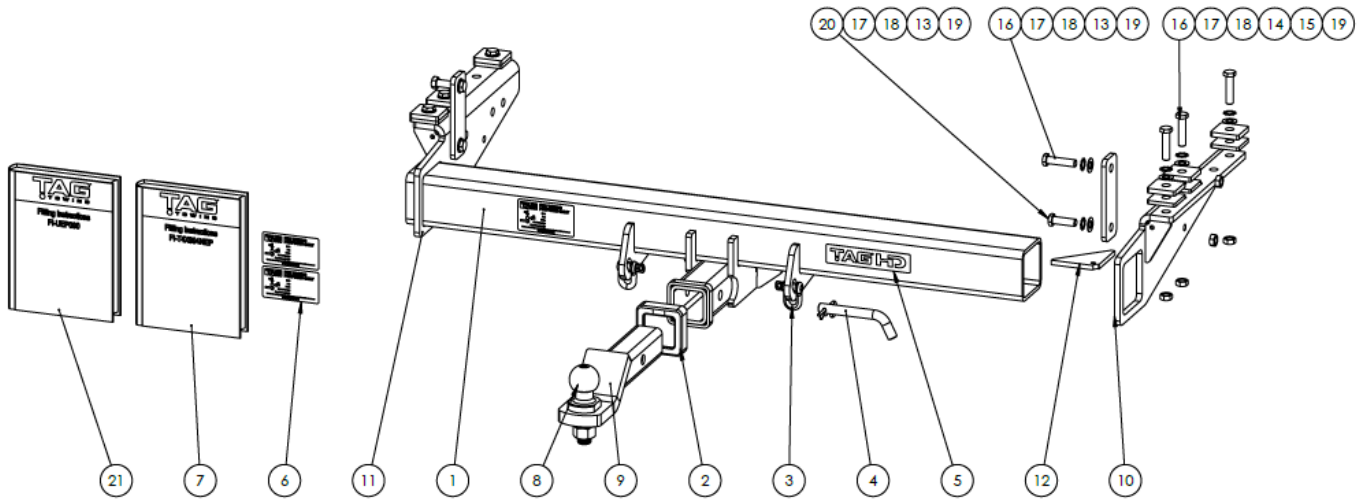

ITEM NO.	DESCRIPTION	QTY.	ITEM NO.	DESCRIPTION	QTY.
1	Towbar Assembly	1	12	Gusset Triangle -(82x82x8mm)	2
2	TAG Hitch Cover	1	13	Auxiliary Side Mounting Plate	2
3	D-Shackle - 10mm. 1000kg	2	14	50x50x8 Single Hole Top Plate	6
4	Class 4 Pin & Clip	1	15	50x50x6 Single Hole Top Plate	6
5	TAG HD Sticker 150 x 33mm	1	16	M12 x 1.25 x 50 Hex Bolt	8
6	Compliance Label	3	17	M12 Shakeproof Washer	10
7	Fitting Instruction	1	18	1/2" Flat Washer	10
8	50mm TAG Tow Ball - Chrome	1	19	M12x1.25 Nut	10
9	L4045 POWDER COATED TBM	1	20	M12 x 1.25 x 40 Hex Bolt	2
10	End Plate Assembly - PS	1	21	Fitting Instruction	1
11	End Plate Assembly DS	1			

Important Information



Warning:

- This product is for towing purposes only and must only be loaded as shown in your vehicle Owner's Manual.
- This towbar is NOT to be drilled, cut, welded, or modified in any way.
- Check behind chassis rail and body panels before drilling to ensure no hazards are present.
- All load ratings shown are under the assumption your trailer has a functional braking system installed.
- When installed in positions other than the one depicted in these instructions the Tow Ball Mount may interfere or obstruct certain features of your vehicle (tailgate opening, Chassis clearance, etc.)

General:

- Before fitting this towbar read fitting instructions and check installation hardware is correct.
- Check that the towbar is suitable for the vehicle and be wary of any changes to the vehicle design that may conflict with the fitting of this towbar. (Tray, Canopy, Suspension etc.)
- After drilling, blow any filings clear, remove any burrs and treat exposed metal with a rust inhibitor.
- The high tensile fasteners supplied with this product are an integral feature to achieving the specified rating, if replacement is required ensure that fasteners of the same grade (8.8) & quality are used. Contact an authorised TAG distributor or the TAG fitment center - (07) 3208 3022 - if further information is required.

Towbar Maintenance and Care:

It is recommended, when not in use, that the Tow Ball Mount assembly and class 4 Pin and Clip is stored inside the car away from moisture to prevent standing water from forming rust. Inspect to ensure, on regular basis, fasteners are torqued to the specifications below and in good condition.

Ensure that the fitting instructions are read and understood prior to fitment, Following the fitment place these instructions in the vehicle's glovebox after installation is completed.

Metric Bolt Torque Settings

Diameter	Pitch	Grade	Torque	Unit		Diameter	Pitch	Grade	Torque	Unit
M8	1.25	8.8	29	Nm		M12	1.25	10.9	125	Nm
M10	1.25	8.8	57	Nm		M12	1.50	10.9	105	Nm
M10	1.50	8.8	44	Nm		M14	1.25	10.9	195	Nm
M12	1.25	8.8	101	Nm		M14	1.50	10.9	165	Nm
M12	1.50	8.8	97	Nm		M16	1.25	10.9	295	Nm
M12	1.75	8.8	77	Nm		M16	1.50	10.9	250	Nm
M14	2.00	8.8	122	Nm		50mm Tow Ball	N/A	N/A	300	Nm
M16	2.00	8.8	190	Nm		70mm Tow Ball	N/A	N/A	750	Nm

Important Information



Please Note: If your vehicle GVM is as listed below and is towing with a 50mm tow ball, the tow rating with reduce as follows

Vehicle GVM (kg)	50mm Tow Ball Rating (kg)		Trailer Coupling Rating (kg)	
	3500kg Rated	750kg Rated	2000kg Rated	3500kg Rated
5000	3500	750	2000	3500
5500	3241	750	1928	3241
6000	3089	745	1873	3089
6500	2972	738	1829	2972
7000	2878	732	1793	2878
7500	2801	727	1763	2801
8000	2737	722	1737	2737
8500	2683	718	1715	2683
9000	2637	715	1696	2637
9500	2597	712	1680	2597
10000	2562	709	1665	2562
10500	2531	707	1652	2531
11000	2503	705	1640	2503
11500	2479	703	1630	2479
12000	2457	701	1620	2457
12500	2437	699	1611	2437
13000	2419	698	1603	2419
13500	2402	697	1596	2402
14000	2387	695	1589	2387
14500	2373	694	1583	2373
15000	2360	693	1577	2360
15500	2348	692	1572	2348
16000	2337	691	1567	2337
16500	2327	690	1562	2327
17000	2317	689	1558	2317
17500	2308	688	1554	2308
18000	2300	688	1550	2300
18500	2292	687	1547	2292
19000	2284	686	1543	2284
19500	2277	686	1540	2277
20000	2271	685	1537	2271
20500	2264	685	1534	2264
21000	2258	684	1531	2258
21500	2253	683	1529	2253
22000	2247	683	1526	2247
22500	2242	682	1524	2242



Step 1: Prepare for Fitment

- a. Using Vise grips clamp the end plate assemblies to the underside of the chassis. If there are any protrusions preventing the end plate from sitting flush to the chassis use the spacer plates provided to avoid these features. These plates can be tacked welded to the end plates to aid in fitment, just be sure to line the holes on plate up to the holes in the end plate.
- b. Attach the auxiliary mounting plates to the outside of the end plate and line up to the closed side of the chassis rail and measure from the rear of the chassis to ensure both end plates are spaced from the rear of the vehicle equally.
- c. Insert the center section into the endplates and measure from each end plate to the hitch box to ensure hitch box is centralized between the endplates. Also check to ensure the center section is parallel to the rear of the vehicle.
- d. Make a mark on the center section indicating where the end plates are located. While here ensure that the gussets provided can be installed and do not interfere with any functions of the vehicle, Mark position (End plates may be shortened if necessary).
- e. Remove the center section from the end plates and remove the paint around the area the marks were made on both center section and end plates to accommodate welding.
- f. Re-centralize the center section in the end plates and tack weld in place
- g. Drill hole positions from end plates and auxiliary plates into the chassis to accommodate 4 bolt sets on each side.

Step 2: Weld Towbar

- a. Remove towbar from the chassis
- b. Install a spreader bar between the end plates to reduce distortion
- c. Weld around the perimeter of the intersection between the end plates and center section on both sides of the end plate
- d. Locate and weld the gussets onto the towbar as well
- e. After cooling, remove the spreader bar

Step 3: Instal Towbar

- a. Fit the towbar to the vehicle using the bolts and remaining plates provided from the inside of the chassis
- b. When all hardware has been placed torque them to their specified value on pg.3

Installation Instructions



Step 4: Complete Towbar & Apply Spare Compliance Label

- a. Attach TAG Hitch cover with rubber mallet carefully to prevent breaking.
- b. Attach Tow ball to Ball Mount and slide into receiver. Secure with Pull pin and Clip if you are going to tow straight away. Alternatively, secure the Ball Mount in a safe place inside your vehicle.
- c. Apply one of the compliance labels to the pillar of the driver's door. Leave the remaining label and the fitting instructions in the vehicle handbook.



TAG Warranty Statement



SWD warrants your TAG Towbar for its full product life under the following conditions:

- You can show proof of purchase.
- The towbar has been correctly installed by a suitably qualified installer.
- The towbar has not been modified or abused in any way and has only been used for the purpose intended.
- The towbar was not fitted second hand to your vehicle.

The extent of this warranty includes materials and workmanship used in the manufacture of the towbar and is to the equivalent value of current, full replacement cost.

Nothing stated or implied in this warranty limits in any way, the statutory rights that you may have.

To make a claim visit the original installer in the first instance or, if you are unable to or are not satisfied with their help, then contact us direct by phone on 1300 669122 or visit www.swd.com.au.